



SWIFT. SILENT. SECURE.

SPACER KIT 3/4" (For BMS Jack Plate) **INSTRUCTIONS**

Hardware (included):

A (2) Aluminum Spacers

Installation Tools:

- 3/4" Socket with Ratchet
- 3/4" Wrench

A



If any hardware is missing from this package please contact our Technical Support Team immediately at

1 + 813.689.9932 Option 2

Installation Instructions

- Step 1** Place adapter plate and 3/4" spacer (A) between motor and jack plate with 3/4" spacer (A) against jack plate. **FIG. A-1**
- Step 2** On the opposite side, place (adapter plate shim) and 3/4" spacer (A) between motor and jack plate with 3/4" spacer (A) against jack plate and shim against 3/4" spacer (A). **FIG. A-1**
- Step 3** Finish by tightening all outboard motor bolts back to boat manufacturer's torque specifications.

Example: Port side adapter plate installation diagram

Figure A-1

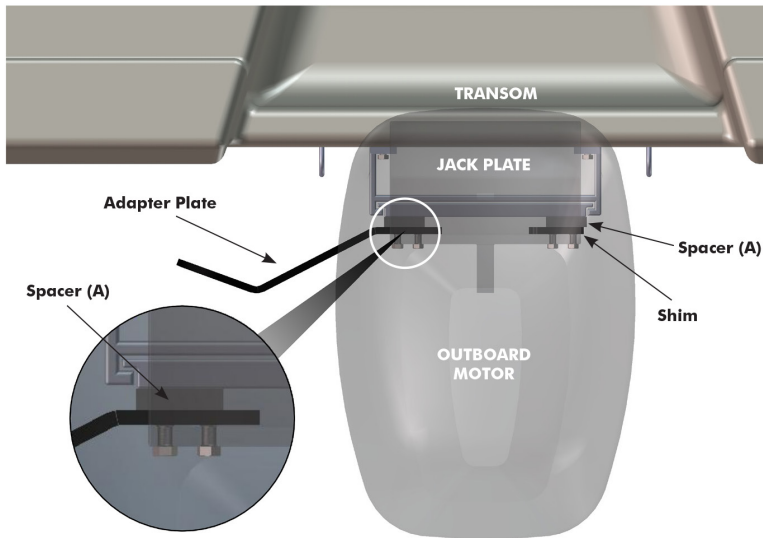

For Technical Support Call 813-689-9932 opt 2